

NEWTEC WEIGHING MACHINE 4014XB1

VERY HIGH
SPEED FOR
LARGE AND EXTRA
LARGE PRODUCTS

ALSO AVAILABLE
FOR CARROTS

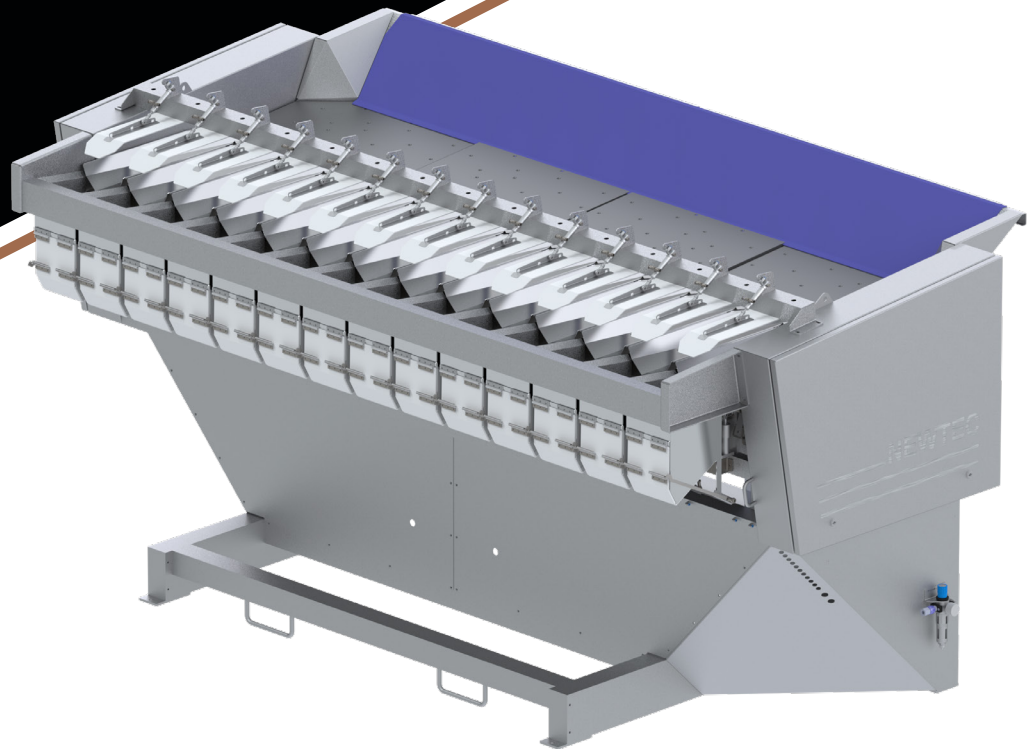

High capacity for large and extra large products and portions

Advantages

- Large weigh heads for large products and portions
- High weighing accuracy: Typical giveaway: less than 0.2%
- High speed – up to 22 portions / min. at 25 kg.
- Option: Newtec WebServices for remote servicing, data collection and analysis
- Option: Newtec MachineLink for easy control of more Newtec machines from only one touchscreen

Application

Large products such as:

- Potatoes • Carrots (G-model) • Onions • Citrus
- Similar fruits and vegetables



WEBSERVICES AVAILABLE
FOR REMOTE SERVICING

YOUR ADVANTAGES

- Robust stainless steel construction
- Heavy duty vibrator lanes to feed product into each weigh head
- With extra large weigh heads to prevent bridging of products
- Easy access for cleaning and service
- Low cost of ownership

AVAILABLE FOR CARROTS (G-MODEL)

OPTION

- Model 4014XB1G for carrots
- Unique feature for optimal alignment and distribution of the carrots

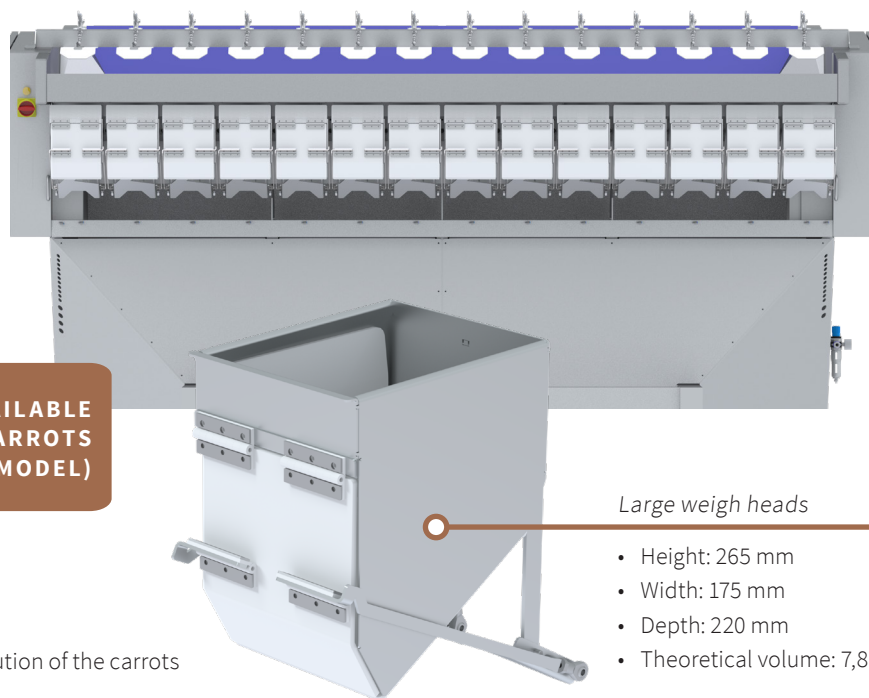

Large weigh heads

- Height: 265 mm
- Width: 175 mm
- Depth: 220 mm
- Theoretical volume: 7,8 L

NEWTEC SOFTWARE

- Intuitive user interface
- Informative and upgradable
- Same user interface on all Newtec weighing and packing machines

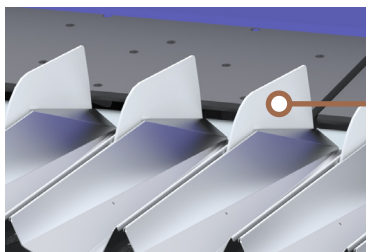

Carrot divider

WEIGHING MACHINE WITH 14 CHANNELS

| | |
|-------------------------------|---|
| Speed / Capacity | Up to 22 portions / min. at 25 kg. |
| Portion sizes | 1 - 25 kg. (depending on product) |
| Weigh head volume | 6 L. |
| Weigh head width | 175 mm. |
| Material | According to the EU/FDA rules on food contact materials |
| Protection class | IP54 |
| Air requirement | |
| Connection | 3/8" |
| Min. pressure | 6 bar (0.6 Mpa) |
| Consumption | 100 NL/min. |
| Electrical requirement | 3 x 220 VAC or 3 x 400 VAC (N) PE 50/60 Hz 3-6kW |
| Environment | 5°C – 40 °C |
| Weight | 900 kg. (excl. portion collection system) |

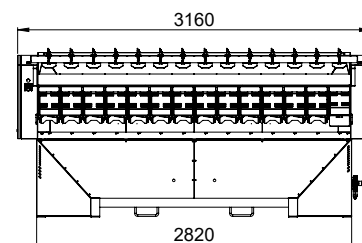
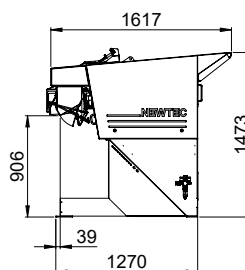

CAPACITY PORTIONS / MIN. POTATOES UP TO:

| | |
|---------|----|
| 1 kg. | 85 |
| 2.5 kg. | 85 |
| 5 kg. | 60 |
| 10 kg. | 50 |
| 25 kg. | 22 |

