

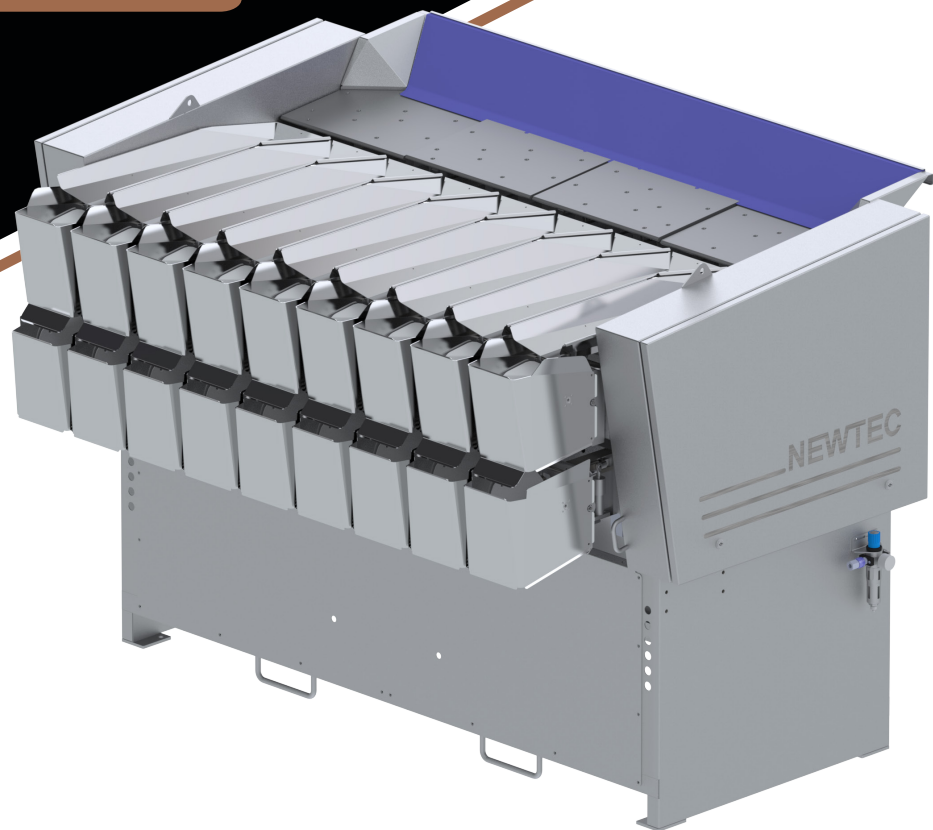

NEWTEC WEIGHING MACHINE 4009XB2

LARGER
PRODUCTS AND
PORTIONS

ALSO AVAILABLE
FOR CARROTS



High speed & weighing accuracy

Advantages

- High weighing accuracy: Typical giveaway: less than 0.2%
- High speed – up to 50 portions / min. at 2,5 kg.
- Flexible system to handle large as well as small vegetables and fruits
- Gentle product handling with low drop height
- Option: Newtec WebServices for remote servicing, data collection and analysis
- Option: Newtec MachineLink for easy control of more Newtec machines from only one touchscreen

Application

Washed vegetables and fruits such as:

- Potatoes • Carrots (G-model) • Onions
- Citrus • Similar fruits and vegetables



WEBSERVICES AVAILABLE
FOR REMOTE SERVICING

YOUR ADVANTAGES

- Robust stainless steel construction
- No tools required for dismantling and assembly of weigh pans
- Easy access for cleaning and service
- Small footprint
- Low cost of ownership

SOLUTION FOR CARROTS (G-MODEL)

OPTION

- Model 4009XB2G for carrots
- With a unique feature for optimal alignment and distribution of the carrots

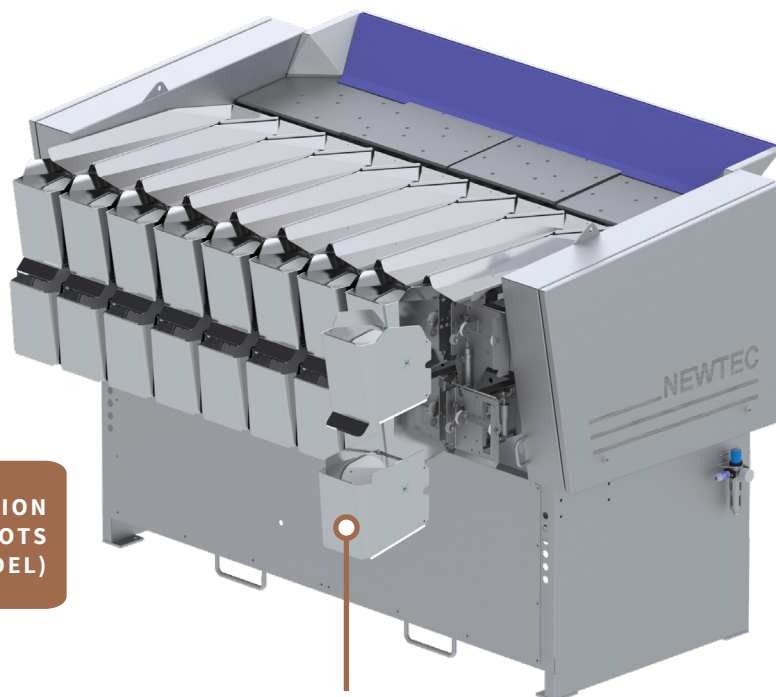

Detachable weigh heads

NEWTEC SOFTWARE

- Intuitive user interface
- Informative and upgradable
- Same user interface on all Newtec weighing and packing machines

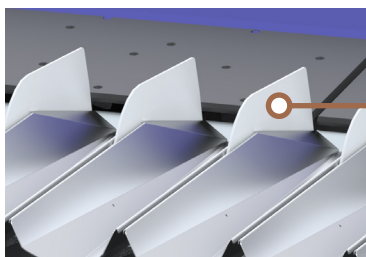

Carrot divider



WEIGHING MACHINE WITH 9 CHANNELS

Speed / Capacity	Up to 50 portions / min. at 2,5 kg.
Portion sizes	0.5 - 5 kg. (depending on product)
Weigh head volume	4 L.
Weigh head width	180 mm.
Material	According to the EU/FDA rules on food contact materials
Protection class	IP54
Air requirement	
Connection	3/8"
Min. pressure	6 bar (0.6 Mpa)
Consumption	65 NL/min.
Electrical requirement	3 x 220 VAC or 3x400 VAC (N) PE 50/60 Hz 3-6kW
Environment	5°C – 40 °C
Weight	650 kg. (excl. portion collection system)

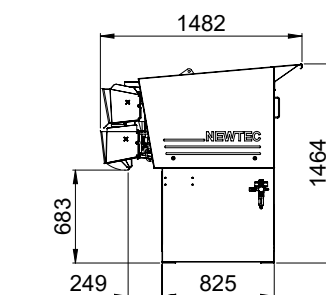

CAPACITY POTATOES UP TO:

CAPACITY	PORTIONS / MIN.
0.5 kg.	55
1 kg.	53
2.5 kg.	50
5 kg.	43

