

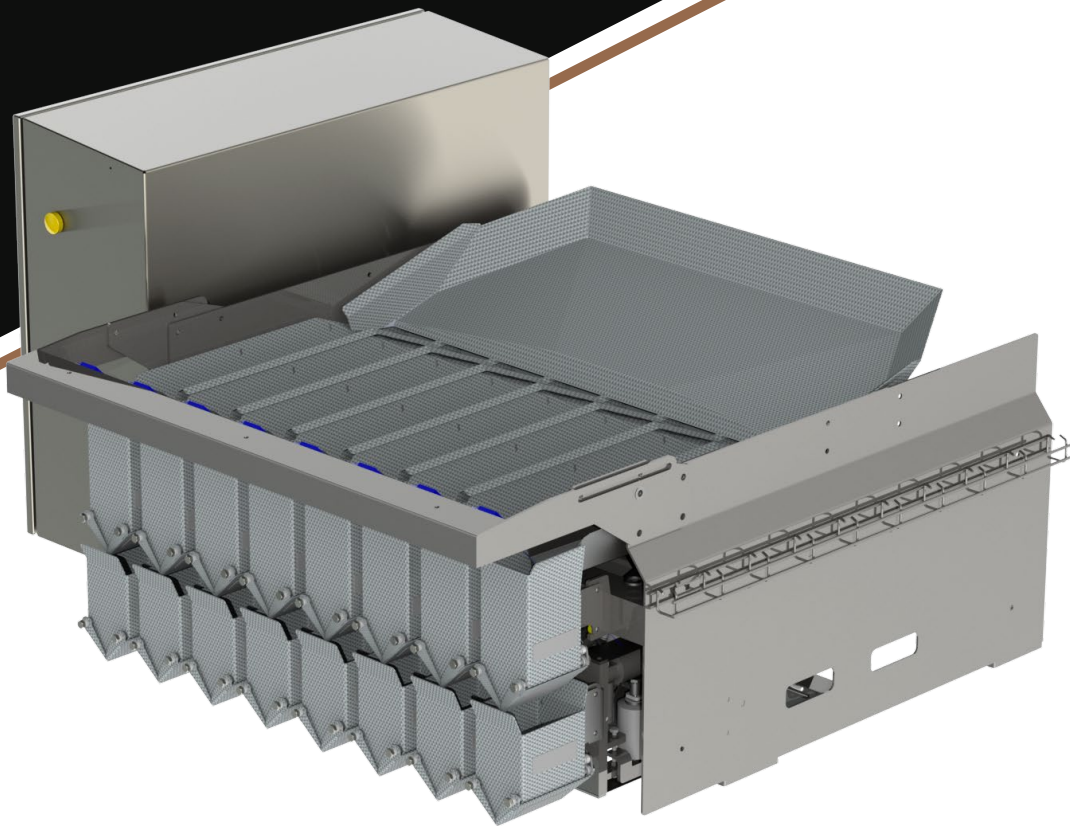

NEWTEC WEIGHING MACHINE 2008PCM

16-CHANNEL
SOLUTION:
2X2008PCM

OPTION



Complex weighing made easy

Advantages

- High weighing accuracy: Typical giveaway: less than 0.4%
- High speed – up to 70 portions/min. at 50 g to 500 g
- Small machine with low product drop height
- Removable chutes for cleaning
- WebServices available for remote servicing and for capturing production data
- MachineLink enabled - from only one touchscreen, either on our weighing machine or Check Point, recipe change and start/stop for both machines is possible

Application

Processed food such as:

- Fresh cut fruits
- Snack products
- Small frozen products
- Similar small products



WEBSERVICES AVAILABLE
FOR REMOTE SERVICING

YOUR ADVANTAGES

- Quick dismantling and assembly of weigh pans and vibrator chutes – no tools required
- Easy access for cleaning and service
- Protection class: IP65

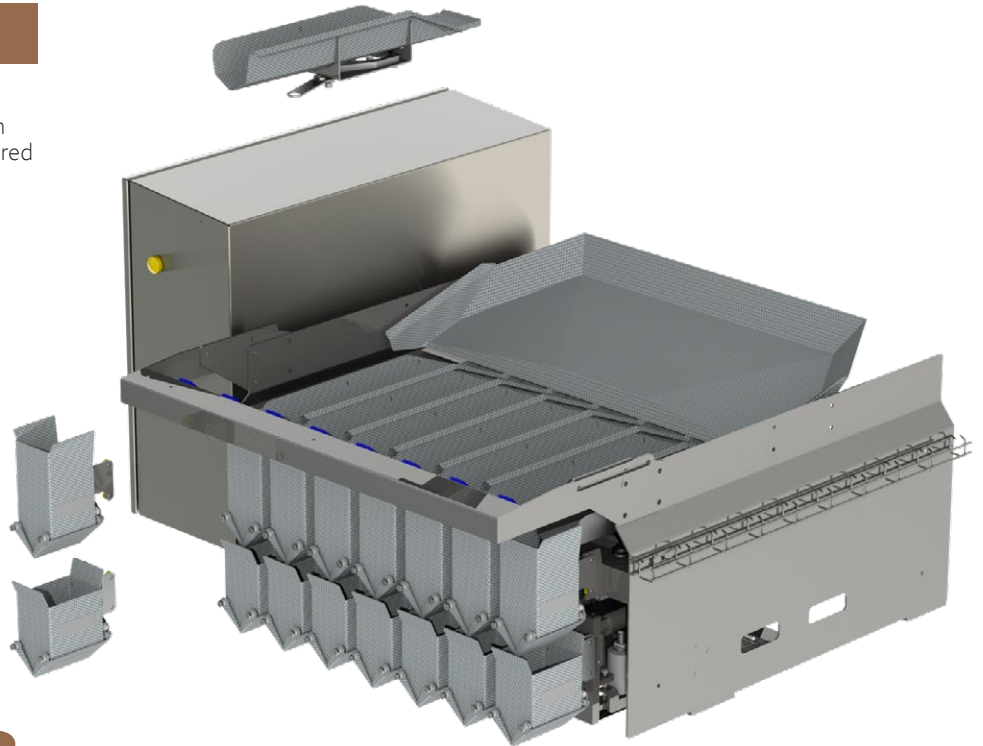

**EASY ACCESS
FOR CLEANING
AND SERVICE**

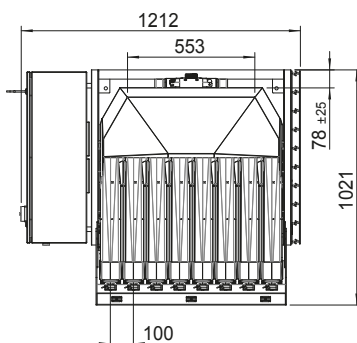
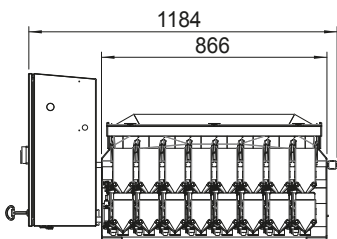
COMBINATION WEIGHER WITH 8 CHANNELS

Speed	High speed – up to 70 portions
Capacity	50 g – 500 g
Weigh pan volume	0.5 L
Designed for	Check weigher solution
Material	According to the EU rules on food contact materials
Air requirement	
Connection	3/8"
Min. pressure	6 bar (0.6 Mpa)
Consumption	25-50 NL/min.
Electrical requirement	3x230 VAC or 3x400 VAC (N) PE 50/60 Hz 1.5 kW
Environment	5°C – 40 °C
Weight	Approx. 280 kg

NEWTEC SOFTWARE

- Intuitive user interface
- Informative and upgradable
- Same user interface on all Newtec weighing and packing machines

