

# NEWTEC WEIGHING MACHINE

## PCF-SERIES

2009PCB-2BRF, 2014PCB-2BRF

WIDTH OF WEIGH HEADS  
152 MM  
HEIGHT OF WEIGH HEADS  
375 MM

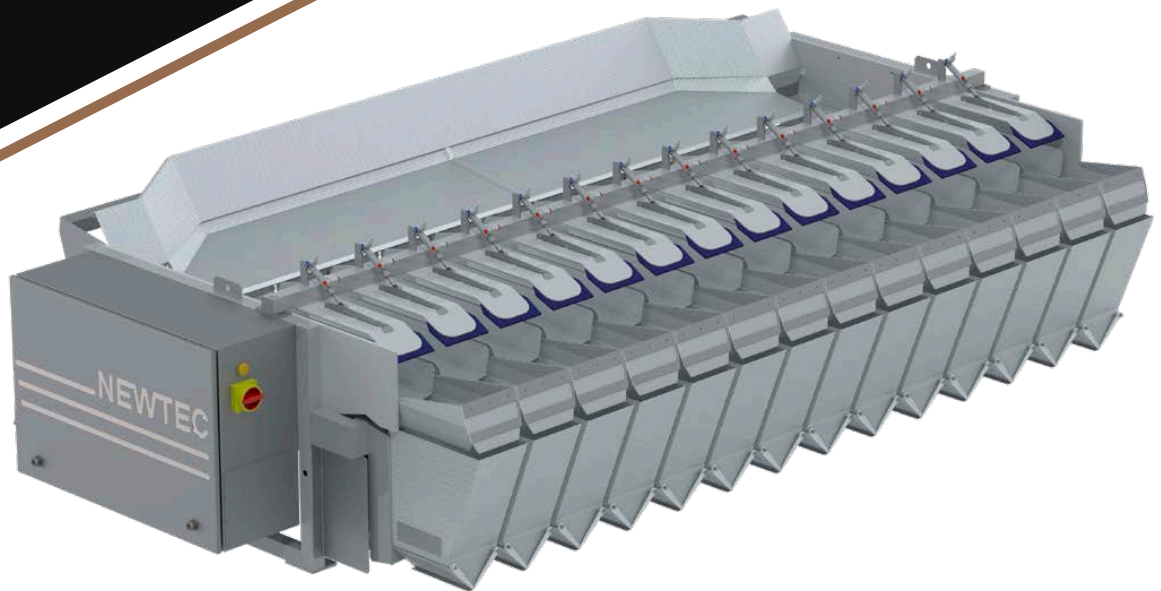

## Accurate combination weighing of long frozen fish

### Advantages

- Combining speed and weighing accuracy
- High weighing accuracy: Typical giveaway: less than 0.4%
- High speed – up to 35 portions/min. at 1 kg (2014PCB-2BRF)
- Vibrator chutes for optimal distribution of products to the weigh heads
- Detachable weigh heads for easy cleaning
- Rigidised stainless steel on all surfaces with food contact to minimize bridging of products
- Option: Newtec WebServices for remote servicing, data collection and analysis
- Option: Newtec MachineLink for easy control of more Newtec machines from only one touchscreen

### Application

- Long frozen fish fillets • Frozen fish and similar products



WEBSERVICES AVAILABLE  
FOR REMOTE SERVICING

## YOUR ADVANTAGES

- User friendly software  
– programmable in seconds
- Count by weight, minimum weight or average weight programs
- Capable of running with one or more channels disabled
- Removable weigh heads  
– no tools required
- Easy access for cleaning and service
- Low friction surfaces

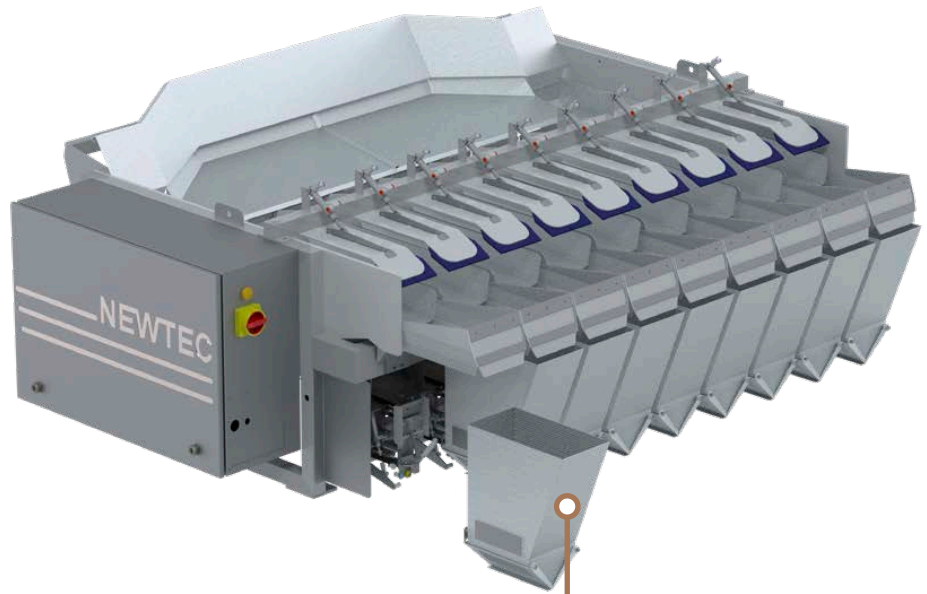

Detachable weigh heads

- Height: 375 mm
- Width: 152 mm
- Depth: 200 mm
- Theoretical volume: 12,4 L

RIGIDISED STAINLESS STEEL

## COMBINATION WEIGHING MACHINE WITH 9 / 14 CHANNELS

Model	2009PCB-2BRF	2014PCB-2BRF
<b>Speed / Capacity</b>	Up to 25 portions/ min. at 1 kg.	Up to 35 portions/ min. at 1 kg.
<b>Weight</b>	410 kg. (excl. portion collection system)	610 kg. (excl. portion collection system)

**Portions sizes** Depending on product

**Air requirement**

<b>Connection</b>	3/8"
<b>Min. pressure</b>	6 bar (0.6 Mpa)
<b>Consumption</b>	25-50 NL/min.

<b>Weigh head volume</b>	12,4 L
<b>Weigh head width</b>	152 mm

**Material** According to the EU/FDA rules on food contact materials

**Protection class** IP65

**Electrical requirement** 3x220 VAC or 3x400 VAC (N)+PE

**Environment** 5° C – 40° C

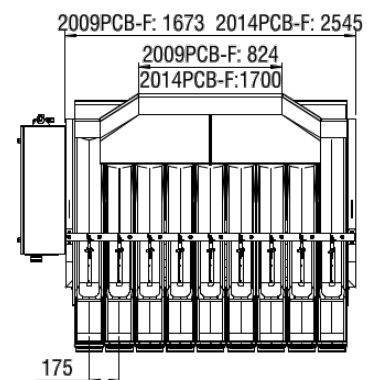
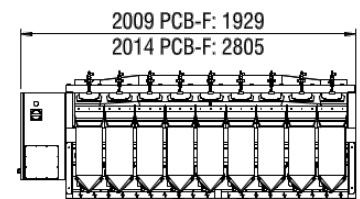
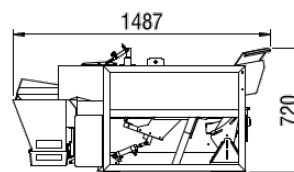

## NEWTEC SOFTWARE

- Intuitive user interface
- Informative and upgradable
- Same user interface on all Newtec weighing and packing machines

